

Technical specifications	AVANT 216	AVANT 220
Engine	Honda GXV530	Kohler V20
Fuel	Petrol	Petrol
Engine output	16 hp	20 hp
Cooling system	Air	Air
Max. drive speed	0 - 10 km/h	0 - 10 km/h
Max. pulling force	600 daN	620 daN
Hydraulics		
• Drive	Direct hydrostatic 4 wheel drive with 4 hydr. motors	
• Auxiliary hydraulics	23 l/min 185 bar	29 l/min 185 bar
Max. lift capacity	350 kg	350 kg
Turning radius	2100 mm	2100 mm
Tyres	20 x 8.00 - 10 Grass or 21 x 8.00 - 10 TR	
Weight	590 kg	620 kg

## TECHNICAL DATA

### Continuous four wheel drive

The continuous four wheel drive of the **AVANT** guarantees a superior pushing force.

### Transmission

**AVANT** is equipped with a smooth, stepless hydrostatic transmission. The hydrostatic variable displacement drive pump is pilot operated, as in bigger wheel loaders.

### Powerful auxiliary hydraulics

The auxiliary hydraulics of the **AVANT** are exceptionally powerful compared to the size of the machine. Hydraulic oil cooler is also available for heavy duty use.

### Cab

All controls are ideally positioned in the **AVANT** cab. There is lots of legroom even for taller operators. Visibility to attachments is excellent.

Safety frame with transparent polycarbonate canopy is standard, giving excellent cover and protection

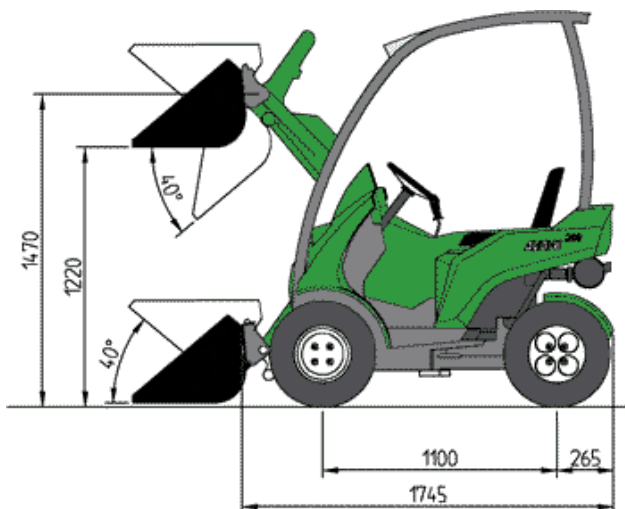

**Kerm Co Limited**

P.O. Box 161, Lewes BN7 9ES

**KERMCO POWERED ACCESS MACHINERY**

Registered Office: Suit 1, Dubarry House, Hove Park Villas, Hove. Registered in England No. 5536451. VAT No. 921 876 016

T/F: 01825 724489 M: 07790 295081

E: [info@kermco.co.uk](mailto:info@kermco.co.uk) [www.kermco.co.uk](http://www.kermco.co.uk)

## OPERATIONAL FEATURES

### Easy to drive

Drive speed is controlled with two pedals: one for driving forward and one for driving backward. The pedals also work like stepless gears: the more the pedal is pressed the faster you will travel. When you lift your foot off the pedal the machine stops and will not move unless the pedal is pressed again. Driving couldn't be easier!

### Controls

Lift arm is controlled with a joystick. Self levelling system makes lifting and lowering of the bucket very easy. Auxiliary hydraulics are controlled with a pedal in the foot well.

### Safety

Unrestricted 360 degree visibility, easy-to-use logical controls, self levelling lift arm and standard extra counterweights in the rear are important built-in safety features of the **AVANT**. Safety frame and canopy provide more safety and also protection against bad weather.

